

The marking on this product doesn't contain environmental hazardous materials per directive 2011/65/EU for RoHS compliance.

ECN NO.	REV.	DESCRIPTIONS	CHECKED	APPROVED	DATE
REL.	AX1	INITIAL RELEASE	FSK	KASUN	07/28/2020

NOTE:

1. THE CABLE ASSEMBLY SHALL BE MEET RoHS2.0 COMPLIANT.
该产品通过RoHS2.0认证.
2. ELECTRICAL AND MECHANICAL PERFORMANCE SHOULD MEET THE PCIE GEN4.0 INDUSTRIAL STANDARD.
电气特性遵循PCIE GEN4.0工业标准.
3. CONNECTER P2 IS ABOVE P3.
注意出线方向,P2在P3的上方.

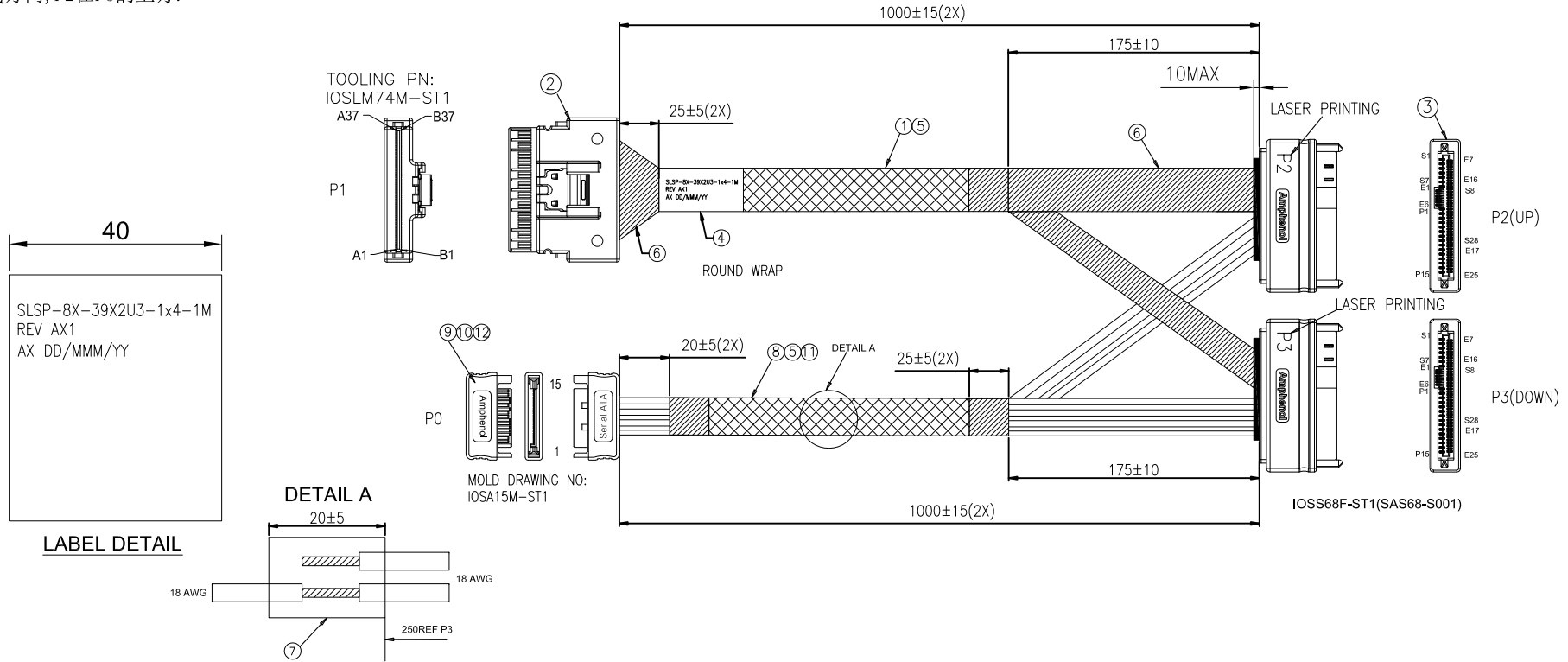

12	HMRPE45NT1	PE:LOW DENSITY,CLEAR,HF	A/R
11	R10070240X	WIRE,24AWG,UL1007,STRANDED	A/R
10	HMRTP45N01	TPE,SHORE 90+/-5A,BLK,R2,HF	A/R
9	(H)10115M03	SATA CONN:15P,M,BRS,Au15,LCP,V0,BLK,HF	1
8	R10070180X	WIRE:18AWG,41C,UL1007,BLK/RED/YEL	A/R
7	HMTNA04003	WIRHS TUBE:ID4.0MM,EVA,BLK,HPF	A/R
6	HMMTP00XXX	TERYLENE CLOTH TAPE,T=0.11mm,BLK,HF	A/R
5	HMTBD07001	EXPANDO TUBE:OD=7MM,BLACK,VW-1,HF	A/R
4	HMLSB40501	LABEL:Synthetic Paper,40*50MM,WHT,BLANK,HF	1
3	AST8639-00X	8639 PCIE 68POS CONN,STR,BLACK,Au15u" HEPCBA0372	2
2	AST8654-0074-01	SLIMSAS 74P CONNECTOR,STR	1
1	HWSS320020	SAS CBL:UL20744,32#2C+2D+A+HM,Sliver plated,85ohm,BLU,VW-1,24G,HF	A/R
ITEM	P/N	DESCRIPTION	QTY

GENERAL TOLERANCES		This drawing is the property of Serial Cables and is delivered on the express condition that it is not to be disclosed, reproduced or used, in whole or in part, for manufacture or sale by anyone other than Serial Cables without its prior consent, and that no right is granted to disclose or use any information in this drawing.	
.X:	± 0.5	DRAWN:	DEVIN ZHOU
.XX:	± 0.3	DATE:	07/28/2020
.XXX:	±	CHECKED:	FSK ZENG
ANGULAR:	±	DATE:	07/28/2020
		APPROVED:	KASUN LI
		DATE:	07/28/2020



Serial Cables
Serial connectivity. Specialized.

TITLE: **SC P/N:SLSP-8X-39X2U3-1x4-1M**
SLIMSAS 8X STR TO 8639*2+SATA

DWG. No.: RSL74-6563

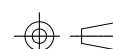
	SCALE: NONE	SHEET 1 OF 3
	UNIT: MM	REV.: AX1

The marking on this product doesn't contain environmental hazardous materials per directive 2011/65/EU for RoHS compliance.

ECN NO.	REV.	DESCRIPTIONS	CHECKED	APPROVED	DATE
REL.	AX1	INITIAL RELEASE	FSK	KASUN	07/28/2020

WIRING DIGARMA

	PERP7	A2	S6	PERp0	<----	
	PERN7	A3	S5	PERn0	<----	
	PERP6	A5	S13	PERp1	<----	
	PERN6	A6	S12	PERn1	<----	
	PERP5	A14	S21	PERp2	<----	
	PERN5	A15	S20	PERn2	<----	
	PERP4	A17	S27	PERp3	<----	
	PERN4	A18	S26	PERn3	<----	
	PETP7	B2	S2	PETp0	---->	
	PETN7	B3	S3	PETn0	---->	
	PETP6	B5	S9	PETp1	---->	
	PETN6	B6	S10	PETn1	---->	
	PETP5	B14	S17	PETp2	---->	
	PETN5	B15	S18	PETn2	---->	
	PETP4	B17	S23	PETp3	---->	
	PETN4	B18	S24	PETn3	---->	
	CONN_CLK_3_P	A8	E1	RefClk1+	---->	
	CONN_CLK_3_N	A9	E2	RefClk1-	---->	
	CONN_CLK_2_P	A11	E7	RefClk0+	---->	
	CONN_CLK_2_N	A12	E8	RefClk0-	---->	
	UP_SCL1	B8	E23	SMClk	---->	
	UP_SDA1	B9	E24	SMDat	---->	
	PORT_RST#_LS_3	B11	E4	ePerst1#	---->	
	PORT_RST#_LS_2	B12	E5	ePerst0#	---->	
	GND	A1	S15/S14	GND	<---->	
	PERP3	A20	S6	PERp0	<----	
	PERN3	A21	S5	PERn0	<----	
	PERP2	A23	S13	PERp1	<----	
	PERN2	A24	S12	PERn1	<----	
	PERP1	A32	S21	PERp2	<----	
	PERN1	A33	S20	PERn2	<----	
	PERP0	A35	S27	PERp3	<----	
	PERN0	A36	S26	PERn3	<----	
	PETP3	B20	S2	PETp0	---->	
	PETN3	B21	S3	PETn0	---->	
	PETP2	B23	S9	PETp1	---->	
	PETN2	B24	S10	PETn1	---->	
	PETP0	B32	S17	PETp2	---->	
	PETN0	B33	S18	PETn2	---->	
	PETP1	B35	S23	PETp3	---->	
	PETN1	B36	S24	PETn3	---->	
	CONN_CLK_1_P	A26	E1	RefClk1+	---->	
	CONN_CLK_1_N	A27	E2	RefClk1-	---->	
	CONN_CLK_0_P	A29	E7	RefClk0+	---->	
	CONN_CLK_0_N	A30	E8	RefClk0-	---->	
	UP_SCL0	B26	E23	SMClk	---->	
	UP_SDA0	B27	E24	SMDat	---->	
	PORT_RST#_LS_1	B29	E4	ePerst1#	---->	
	PORT_RST#_LS_0	B30	E5	ePerst0#	---->	
	GND	A31	S15/S14	GND	<---->	
	GND	A1/A4/A7/A10/A13/A16/A19/A22/A25/A28/A31/A34/A37/B1/B4/B7/B10/B13/B16/B19/B22/B25/B28/B31/B34/B37			<---->	

NOTE:E15(P2/P3) OPEN
E25(P2/P3) NOT CONNECTED WITH GND

P2	E3	P1	P2	P3	P4	P5	P6	P7	P8	P9	P10	P11	P12	P13	P14	P15
P3	E3	P1	P2	P3	P4	P5	P6	P7	P8	P9	P10	P11	P12	P13	P14	P15
P0	1,2,3					4,5,6		7,8,9					10,11,12		13,14,15	
SYMBOL	3.3V					GND		5V					GND		12V	
WIRE AWG	24AWG					18AWG		18AWG					24AWG		18AWG	
WIRE COLOR	ORANGE					BLACK		RED					BLACK		YELLOW	

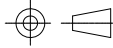
GENERAL TOLERANCES		This drawing is the property of Serial Cables and is delivered on the express condition that it is not to be disclosed, reproduced or used, in whole or in part, for manufacture or sale by anyone other than Serial Cables without its prior consent, and that no right is granted to disclose or use any information in this drawing.			
.X:	± 0.5	DRAWN:	DEVIN ZHOU		
.XX:	± 0.3	CHECKED:	FSK ZENG	DATE:	07/28/2020
.XXX:	±	APPROVED:	KASUN LI	DATE:	07/28/2020
ANGULAR:	±				
TITLE:				SC P/N:SLSP-8X-39X2U3-1x4-1M	
				SLIMSAS 8X STR TO 8639*2+SATA	
DWG. No.:				RSL74-6563	
		SCALE: NONE		SHEET 2 OF 3	
		UNIT: MM		REV.: AX1	

The marking on this product doesn't contain environmental hazardous materials per directive 2011/65/EU for RoHS compliance.

ECN NO.	REV.	DESCRIPTIONS	CHECKED	APPROVED	DATE
REL.	AX1	INITIAL RELEASE	FSK	KASUN	07/28/2020

LABEL 2

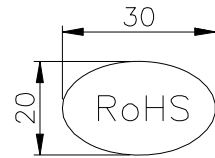
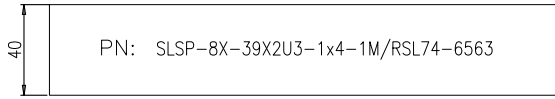

LABEL 3



⑤ The label is stucked in the middle.

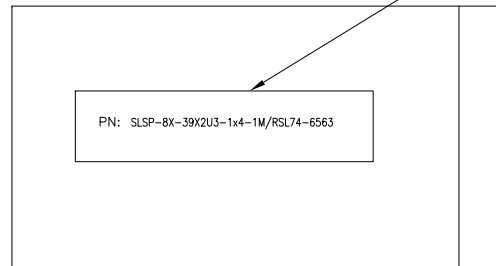

④ 1PCS PRODUCTS PUT INTO PE BAG

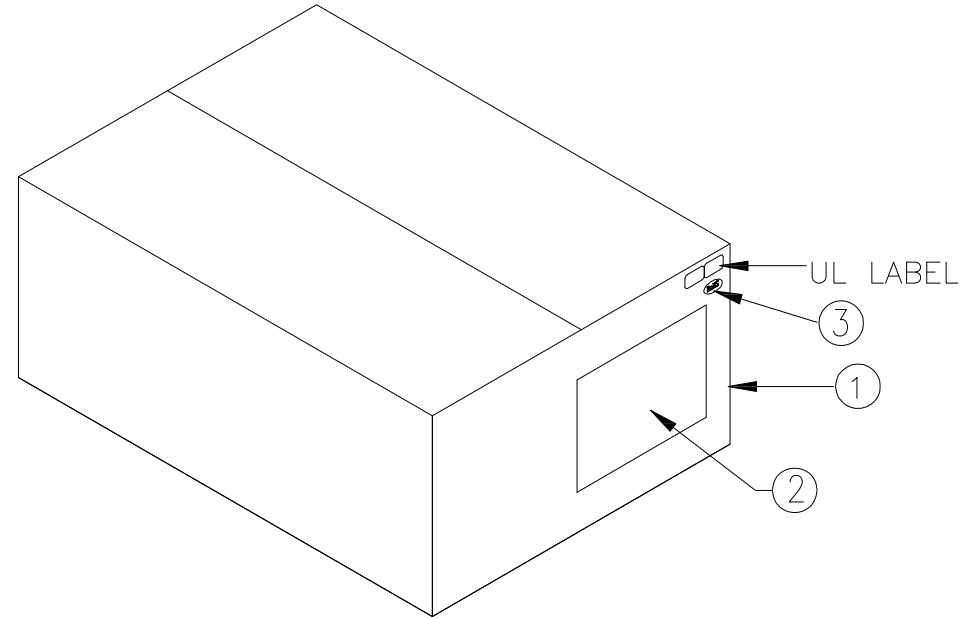

5	HMSB14741	LABEL:Synthetic Paper,14*74MM,WHT,HF	1
4	RMBZIP0018	ZIP BAG:120*300MM,T=6C	1
3	RMSW30201	RoHS LABEL:30*20MM, LABEL3 INFO	1
2	RMSB00401	LABEL:100*40MM,WHT,BLANK,R2	1
1	RMBCTN0019	CARTON:590*240*200MM E TYPE	1
ITEM	PART NUMBER	DESCRIPTION	Q'TY

This drawing is the property of Serial Cables and is delivered on the express condition that it is not to be disclosed, reproduced or used, in whole or in part, for manufacture or sale by anyone other than Serial Cables without its prior consent, and that no right is granted to disclose or use any information in this drawing.



TITLE: **SC P/N:SLSP-8X-39X2U3-1x4-1M**
SLIMSAS 8X STR TO 8639*2+SATA

DWG. No.: RSL74-6563

GENERAL TOLERANCES

.X:	± 0.5
.XX:	± 0.3
.XXX:	±
ANGULAR:	±

DRAWN:	DEVIN ZHOU	DATE:	07/28/2020
CHECKED:	FSK ZENG	DATE:	07/28/2020
APPROVED:	KASUN LI	DATE:	07/28/2020

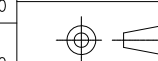

SCALE:	NONE	SHEET 3 OF 3
UNIT:	MM	REV.: AX1