

THIS DOCUMENT CONTAINS PROPRIETARY INFORMATION AND IS THE PROPERTY OF WILDER TECHNOLOGIES. THIS INFORMATION SHALL NOT BE REPRODUCED, TRANSFERRED TO OTHER DOCUMENTS, DISCLOSED TO OTHERS FOR MANUFACTURING OR ANY OTHER PURPOSE WITHOUT WRITTEN PERMISSION FROM WILDER TECHNOLOGIES.

REVISIONS				
REV	AUTH	DESCRIPTION	APVD DATE	CHK DATE
A	ECNXXXX	PRELIMINARY RELEASE		11/25/2013

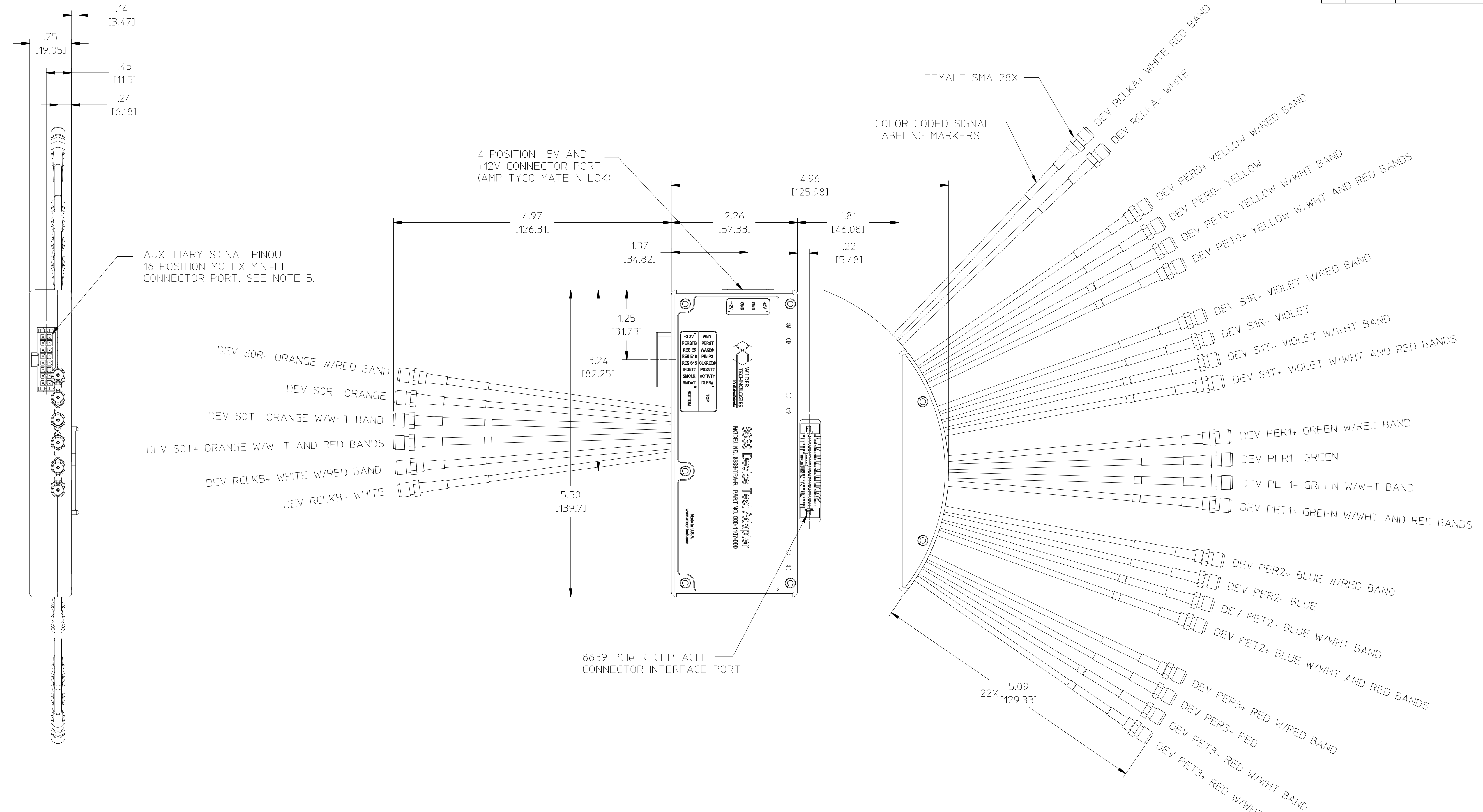

5. A CABLE INTERFACE PLUG CONNECTOR AND CONTACTS FOR THE LOW SPEED CABLE IS PROVIDED WITH THIS ASSEMBLY. MOLEX PART NUMBER 43025-1600 AND CONTACTS 43031-0011 FOR 26-30 AWG WIRE. FURTHER REPLACEMENT CAN BE PURCHASED THROUGH MOLEX DISTRIBUTORS.
4. COLOR CODING BANDS ON CABLES, RED BAND DENOTES POSITIVE BLACK (NO BAND) DENOTES NEGATIVE. SMALL WHITE BANDS DENOTE TRANSMIT SIGNALS.
3. 2 SUPPORT BRACKETS, 4 THUMB SCREWS AND MOUNTING HARDWARE ARE SUPPLIED WITH EACH UNIT. THESE BRACKETS WILL PROVIDE FOR SUPPORT OF DISK DRIVES WHILE UNDER TEST. THIS WILL REMOVE STRESS FROM THE MAIN TEST ADAPTER CONNECTOR, EXTENDING THE LIFE OF THE TEST ADAPTER AND QUALITY OF SIGNAL LINES. SEE SHEET 2.
2. REFER TO THE USERS MANUAL FOR DETAILED MECHANICAL AND ELECTRICAL SPECIFICATIONS.
1. INTERPRET DIMENSIONS AND TOLERANCES PER ANSI Y14.5.

NOTE: UNLESS OTHERWISE SPECIFIED

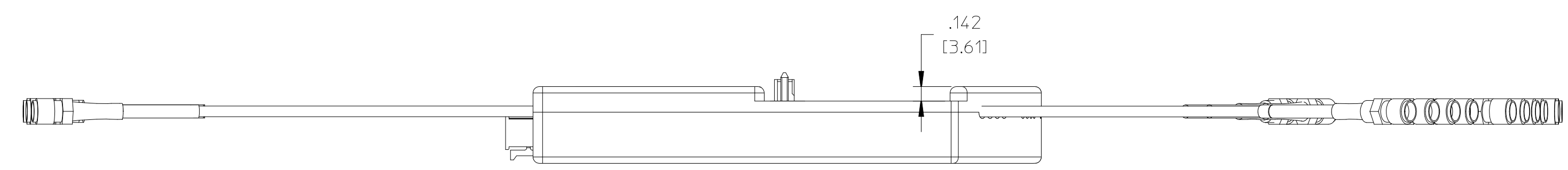

UNLESS OTHERWISE SPECIFIED DIMENSIONS ARE INCHES [METRIC]		WILDER TECHNOLOGIES		6101A East 18th St Vancouver, WA 98661	
XXX ±	.005 ±	.127 ±	Tel: 360-859-3041 Fax: 360-859-3105 www.wildertech.com		
.XX ±	.01 ±	.25 ±	DRAWN BY: W. STANLEY DATE: 11/25/2013		
X ±	.12 ±	.3 ±	CHECKED BY: DATE:		
ANGLE ±	°	°	APPROVED BY: DATE:		
MATERIAL:		DESCRIPTION:			
		FINAL ASSEMBLY, 8639 DEVICE TEST ADAPTER			
FINISH:	SIZE	PART NUMBER:	REV		
	D	600-1107-000_W	A		
SCALE: 1:1		DO NOT SCALE DRAWING		SHEET 1 OF 2	

THIS DOCUMENT CONTAINS PROPRIETARY INFORMATION AND IS THE PROPERTY OF WILDER TECHNOLOGIES. THIS INFORMATION SHALL NOT BE REPRODUCED, TRANSFERRED TO OTHER DOCUMENTS, DISCLOSED TO OTHERS FOR MANUFACTURING OR ANY OTHER PURPOSE WITHOUT WRITTEN PERMISSION FROM WILDER TECHNOLOGIES.

REVISIONS				
REV	AUTH	DESCRIPTION	APVD DATE	CHK DATE

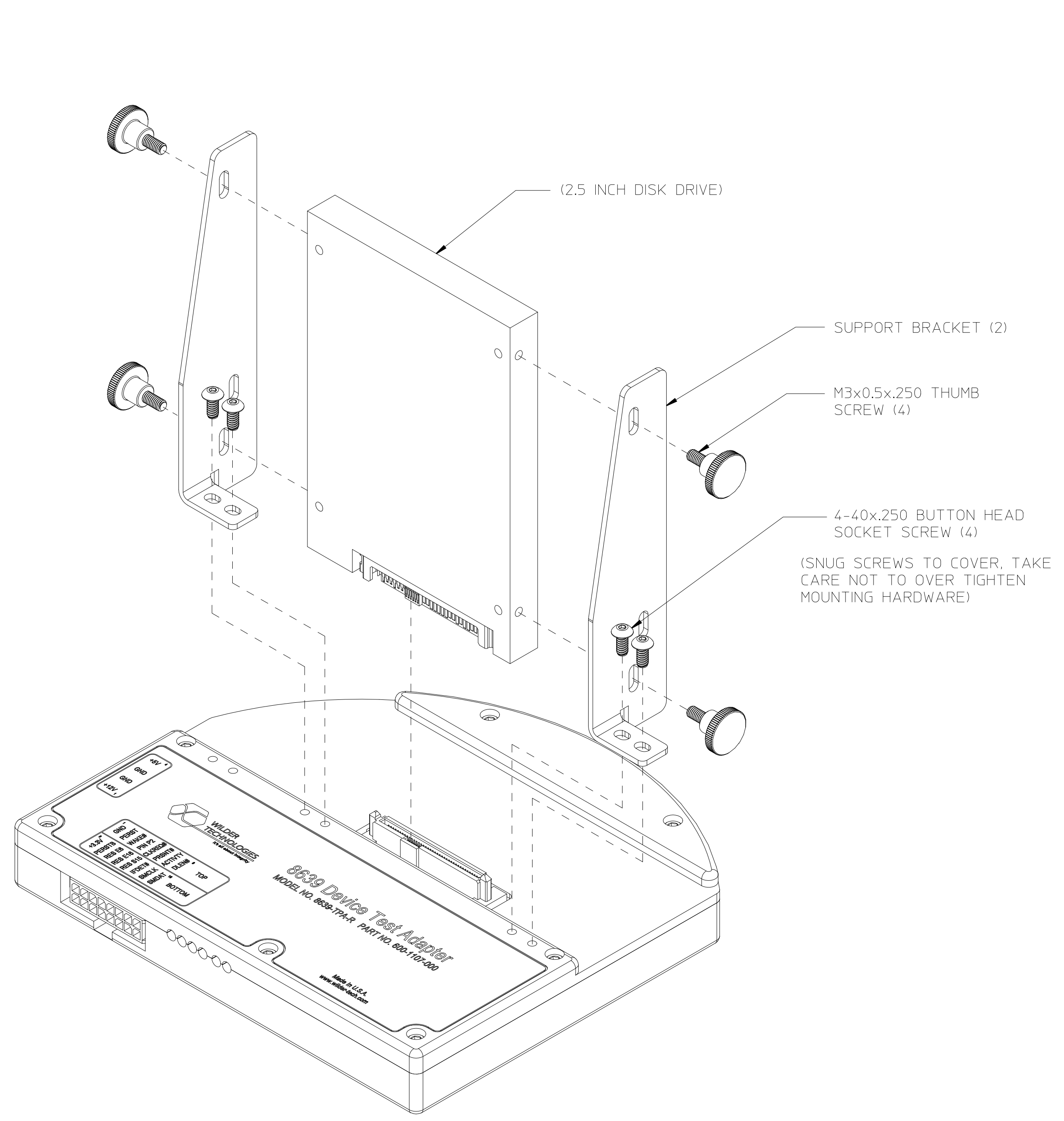

SUPPORT BRACKET INSTALLATION
DETAIL FOR 2.5 INCH DISK DRIVE
(CABLES REMOVED FOR CLARITY)
SEE NOTE 3

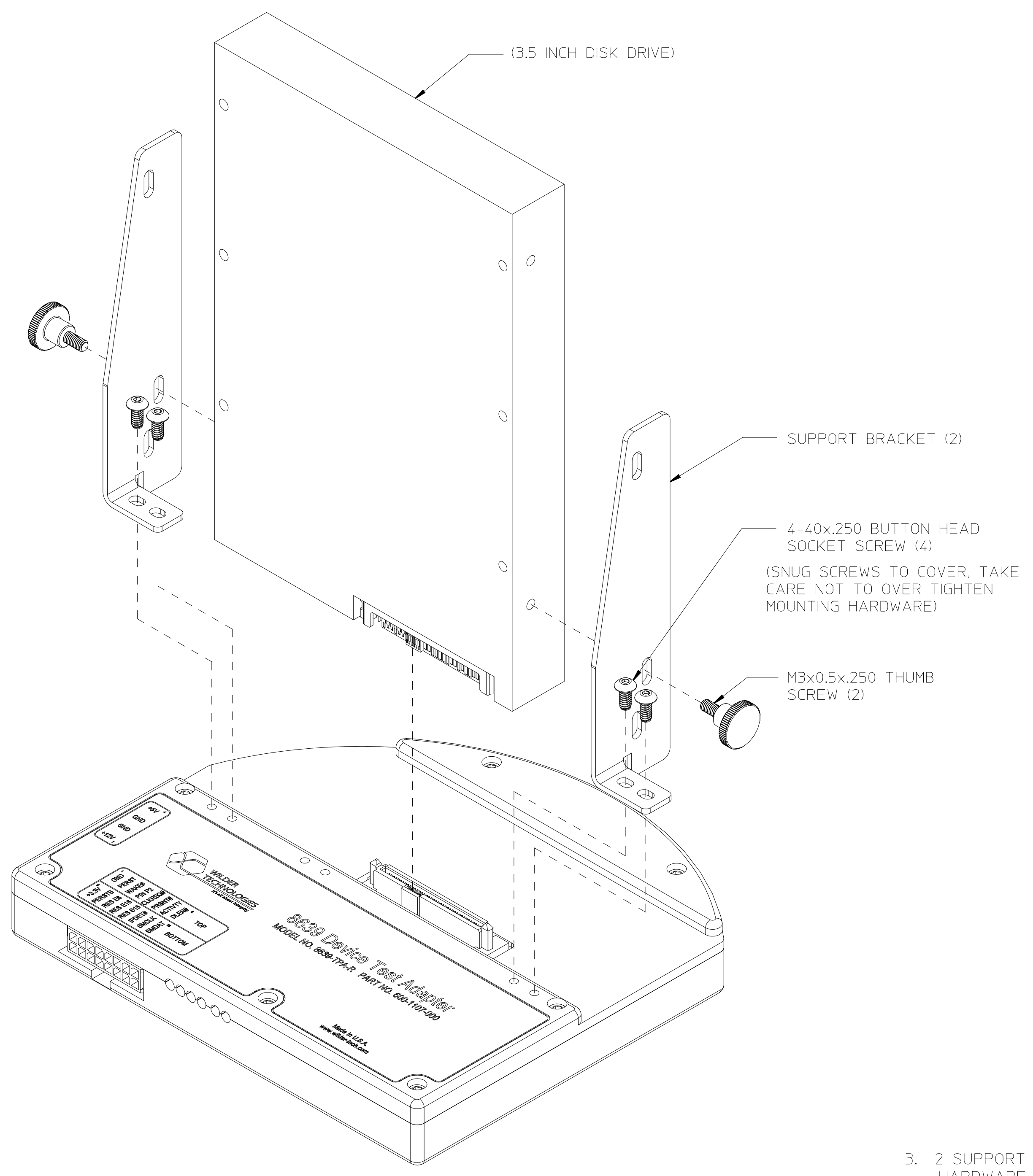

SUPPORT BRACKET INSTALLATION
DETAIL FOR 3.5 INCH DISK DRIVE
(CABLES REMOVED FOR CLARITY)
SEE NOTE 3

3. 2 SUPPORT BRACKETS, 4 THUMB SCREWS AND MOUNTING HARDWARE ARE SUPPLIED WITH EACH UNIT. THESE BRACKETS WILL PROVIDE FOR SUPPORT OF DISK DRIVES WHILE UNDER TEST. THIS WILL REMOVE STRESS FROM THE MAIN TEST ADAPTER CONNECTOR, EXTENDING THE LIFE OF THE TEST ADAPTER AND QUALITY OF SIGNAL LINES.
 2. REFER TO THE USERS MANUAL FOR DETAILED MECHANICAL AND ELECTRICAL SPECIFICATIONS.
 1. INTERPRET DIMENSIONS AND TOLERANCES PER ANSI Y14.5.
- NOTE: UNLESS OTHERWISE SPECIFIED

HARDWARE INSTALLATION DETAILS 2.5 AND 3.5 DISK DRIVES

UNLESS OTHERWISE SPECIFIED DIMENSIONS ARE INCHES [METRIC]		6101A East 18th St Vancouver, WA 98661 Tel: 360-859-3041 Fax: 360-859-3105 www.wilder.tech	
.XX + .005 + .127 +	.XX + .01 + .25 +	DRAWN BY: W. STANLEY DATE: 9/19/2014	
.X + .12 + .3 +	ANGLE + .9°	CHECKED BY: DATE:	
MATERIAL:		APPROVED BY: DATE:	
FINISH:		DESCRIPTION:	
		8639 RECEPTACLE TPA HARDWARE KIT INSTALLATION INSTRUCTIONS	
SIZE	PART NUMBER:	REV	
D	600-1107-000_W	A	
SCALE: 1:1		DO NOT SCALE DRAWING SHEET 2 OF 2	